

# Twin-Screw Extruders

Brabender TwinLab Series



# Elevate Your Extrusion

**Determining extrusion process parameters that lead to perfect results is complex. Anton Paar has the easy answer: TwinLab laboratory and pilot-scale extruders.**

Our range of high-tech measuring extruders provides deep and precise insight into a broad range of process parameters that influence your material. Rapid tests of recipe and parameter adaptations get you to the desired extrusion result within hours instead of days. Smaller extruders with shorter testing times mean a dramatic decrease in expensive sample loss.

- Understand the extrusion process, linking parameters to the final product using live and historical data
- Save testing costs and sample loss by avoiding costly development and experimental testing on large production machines
- Cut expensive downtimes of production extruders to a minimum
- Go from lab to production level in no time thanks to precisely determined process parameters for scale-up
- Conduct sample and formulation testing on a small scale for subsequent investigations



# Your Extrusion Dream Machine

Brabender TwinLab extruders are the best choice for processing polymer, food, and other extrudable materials. From thermoplasts, thermosets, and additives to food samples like snacks and meat analogues, the choice is yours.

Unleash your full scientific potential with customizable screw configurations, specialized barrel and screw materials such as Brabender's patented Bralloy, and a wide range of process peripherals – including dies, film inspection systems, and pelletizing units.

A wide array of steel alloys ensure durability over the whole instrument lifetime – even with highly corrosive and abrasive substances.

- Customize your extruder based on your requirements and material demands
- Collect data and gain material insights based on in-process recording of extrusion parameters
- MetaBridge software: The benchmark for real-time parameter tracking and integrated peripheral data
- Benefit from the advantages of complete solutions offered by an established single supplier
- A clamshell-inspired liner with a horizontal opening mechanism for easy access, facilitating cleaning and monitoring of the screw configuration's effectiveness

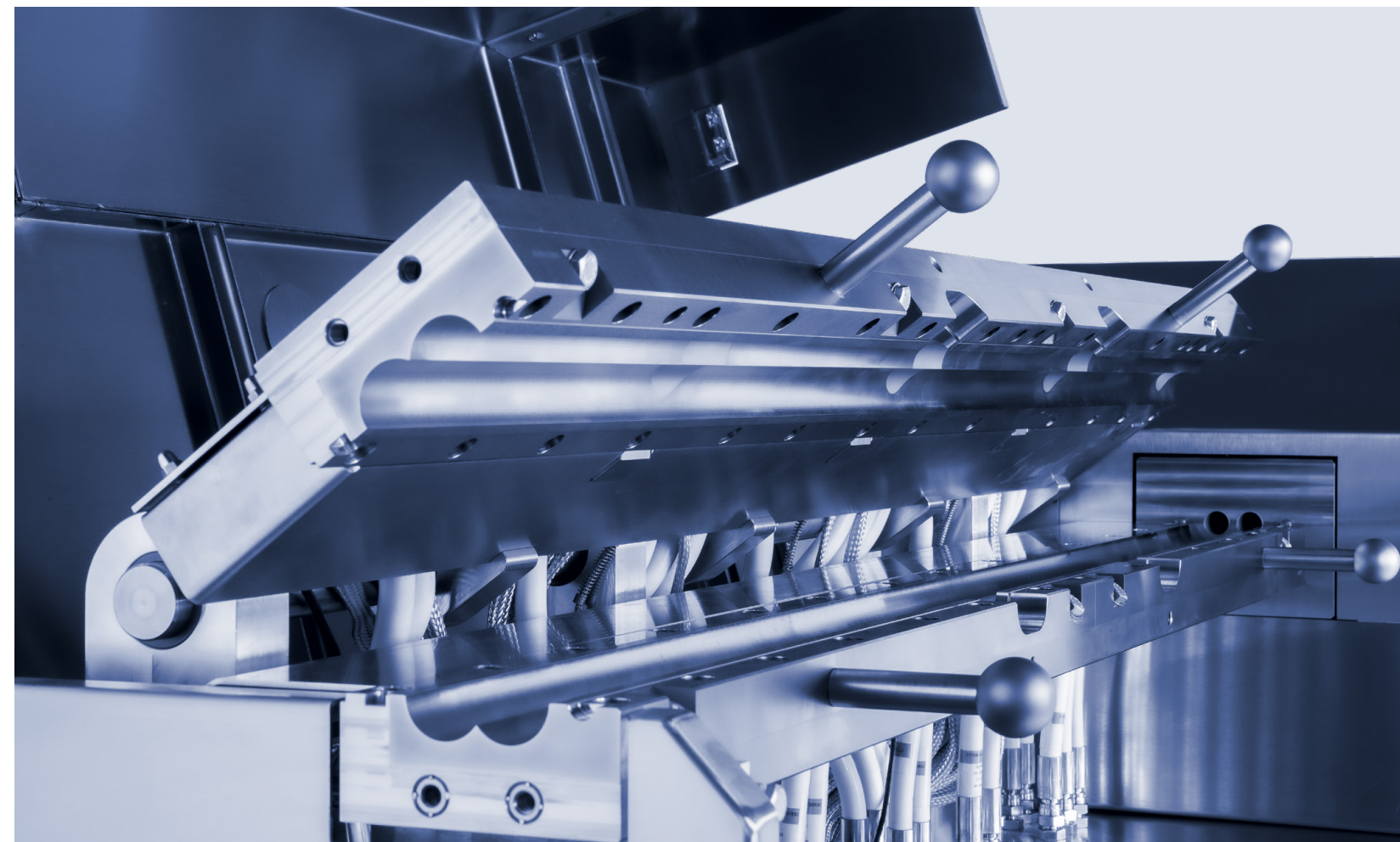

# The TwinLab Series

From laboratory scale to small series production

## TwinLab B-TSE-A 12/36

Twin-screw extruder in modular attachment design for use with the torque rheometer device MetaStation 4 in laboratory applications



## TwinLab B-TSE-A 20/40

Twin-screw extruder in modular attachment design for use with the torque rheometer device MetaStation 8 in laboratory applications



## TwinLab B-TSE-S 20/40

Standalone TwinLab design for laboratory applications



## TwinLab B-TSE-S 30/40

Standalone TwinLab design for pilot applications and small series production



	TwinLab B-TSE-A 12/36	TwinLab B-TSE-A 20/40
<b>Throughput<sup>1</sup></b>	0.06 kg/h to 5 kg/h	0.5 kg/h to 20 kg/h
<b>Screw diameter D</b>	12 mm	20 mm
<b>L/D</b>	36	40
<b>Max. screw torque</b>	2 x 15 Nm	2 x 40 Nm
<b>Max. screw speed</b>	740 min <sup>-1</sup>	1,600 min <sup>-1</sup>
<b>Max. processing pressure</b>	150 bar	300 bar

	TwinLab B-TSE-S 20/40	TwinLab B-TSE-S 30/40
<b>Throughput<sup>1</sup></b>	0.5 kg/h to 20 kg/h	5 kg/h to 100 kg/h
<b>Screw diameter D</b>	20 mm	30 mm
<b>L/D</b>	40	40
<b>Max. screw torque</b>	2 x 40 Nm	2 x 150 Nm
<b>Max. screw speed</b>	1,200 min <sup>-1</sup>	1,200 min <sup>-1</sup>
<b>Max. processing pressure</b>	300 bar	300 bar

<sup>1</sup> Guide value – the real throughput is a material and process-specific variable and can be higher or lower

# Pilot-Scale Extrusion with Lab-Level Control

Bridge the gap between lab development and production with Anton Paar's Brabender TwinLab B-TSE-S 30/40. Delivering pilot-scale performance up to 100 kg/h, it enables meaningful trial quantities and reliable small-batch output without the need to move to a larger line or run costly full-scale trials.

Validate formulations, screw setups, and process conditions while continuously tracking all critical parameters to support both independent use and scale-up scenarios.

Featuring convenient access to liners and screws, as well as the industry-leading MetaBridge extrusion software, TwinLab B-TSE-S 30/40 delivers the process insight and control you need for faster process optimization and confident decision-making.

## Most compact pilot extruder in its class

As the most compact extruder in its class, TwinLab B-TSE-S 30/40 is engineered to fit where other pilot systems can't. Its standalone design with fully integrated drive enables fast installation and easy relocation, allowing teams to quickly switch projects or reconfigure pilot areas while maintaining robust, repeatable operation.

## Push-button access for easy inspection and maintenance

Validate each run faster, maximize uptime, and keep handling safer and more consistent. TwinLab B-TSE-S 30/40 combines a clamshell barrel design that opens at the touch of a button, providing direct access to process areas for quick cleaning, screw changes, and inspection.

## Quick insert changes for maximum uptime

With TwinLab B-TSE-S 30/40's split liner design, inserts are quickly removed without full barrel teardown – reducing maintenance work and turnaround time while keeping runs consistent. Simply loosen a few bolts, exchange the parts, and restart. Insert materials and hardness can be matched to your application to protect against abrasive and corrosive compounds.



## Software-configurable I/O for evolving setups

TwinLab B-TSE-S 30/40's unique engineering interface offers unmatched adaptability, with four sensor and four actuator channels that can be configured in the software, enabling post-purchase changes without hardware modifications. Peripherals and downstream systems are managed digitally – from initial commissioning to ongoing trials – while built-in OPC UA ensures seamless PLC/SCADA integration and future-ready performance.

## MetaBridge: The control center of your extrusion process

MetaBridge provides browser-based access to the extrusion process, enabling live monitoring from any desktop or mobile device and faster coordination across teams. Each run is logged automatically, with exports available in Excel, CSV, or PDF to support traceable reporting. The software detects peripherals on connection, ensuring fast, intuitive, and consistent configuration across setups.

# Ready for What's Next

TwinLab B-TSE-S 30/40 lets you extend and reconfigure your system as processes and test objectives evolve. Configure sensors and actuator channels in the software for seamless integration of peripheral equipment and reassign signals as you need to, for consistent configurations across runs. With MetaBridge as the command center, you can easily manage settings, monitor processes, and continuously log data.

- Modular interface with four digital I/O and four analog inputs/outputs ( $\pm 10\text{ V}$  /  $0\text{-}20\text{ mA}$ )
- Seamless integration of feeders, pumps, downstream equipment, sensors (e.g., temperature, Raman), and third-party peripherals
- Centralized operation and parameter management for all connected devices via MetaBridge
- MetaBridge data-logging hub for continuous tracking of process signals (e.g., liquid titration, extrudate take-off speed)



# Instant Melt Insight, Full Process Clarity

When offline analytics arrive too late, days or even weeks can be lost in iteration loops. The Extruder-Raman system closes this gap by adding real-time chemical and structural insight directly at the melt, enabling faster scale-up, fewer repeats, and more stable product properties.

- In situ Raman tracks composition and homogeneity in real time to spot deviations early and avoid rework
- Live quantification reveals blend ratios and dispersion trends, and enables immediate corrective action
- Real-time crystallinity monitoring links process settings to film properties (optical, mechanical, barrier)
- Early detection of thermally induced changes supports process windows that prevent degradation and scrap



# Get Modular Solutions from a Single Supplier

The TwinLab series integrates the hardware and software of all peripherals and downstream devices into a coherent system with seamless data streams. We configure the twin-screw extrusion setup to your individual requirements and applications.

Get the most complete extrusion line on the market from a single supplier, and have it set up by local experts so it runs for decades to come.

- ✓ Easily integrate feeders, pumps, granulators, take-off units, etc. into the extruder control system
- ✓ Control the extruder peripherals and time-resolved recording of the peripheral process variables via MetaBridge software
- ✓ Leverage the application and process know-how of in-house experts at Anton Paar
- ✓ Benefit from Anton Paar's global service and support network for the entire extrusion line

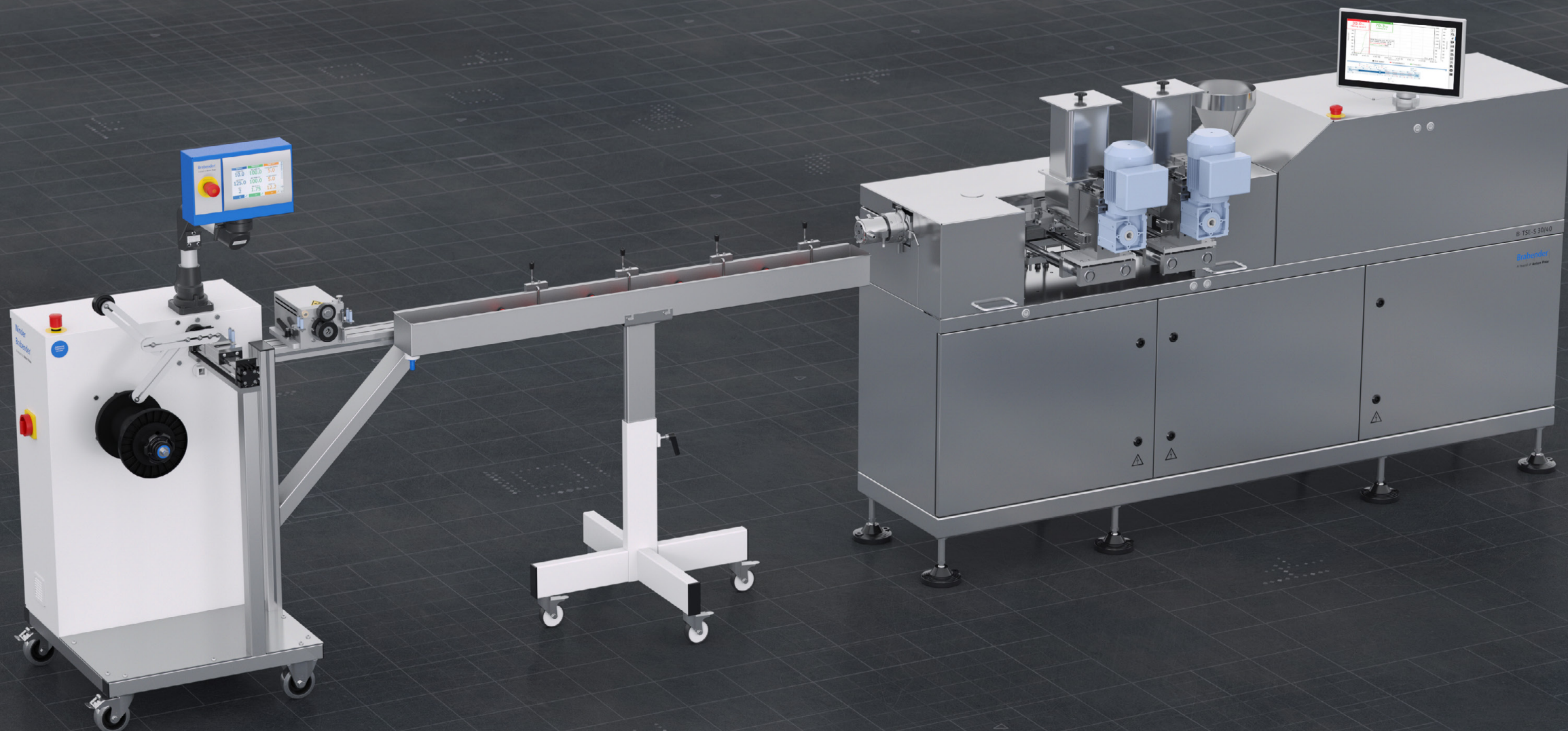

# Meet MetaBridge. Meet the Benchmark.

The MetaBridge operating software is your gateway to critical process data, delivering deep analytical insight and powerful reporting through an intuitive interface. Connect multiple instruments and access data seamlessly – from the instrument, a PC, or a mobile device.

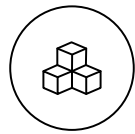

## MetaBridge connect

- Easy access to your measurement data via a web browser within the company network
- Automatic detection of the complete extruder periphery

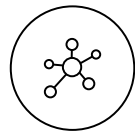

## Data sharing

- Standard data exports in typical formats such as Excel, CSV, PDF
- Built-in mailing function for quick measuring result checks with colleagues and customers
- Support for third-party systems (e.g., LIMS, ERP) via Brabender WebAPI, shared network folders, or OPC UA



## Process editor

- Functionality to define and automate the complete extrusion process
- Complete control of feeder, pumps, temperature, screw speed, etc.
- No human error means increased reproducibility
- Can be easily combined with alarm profiles that automatically monitor the process and trigger an alarm in the unlikely event of an error

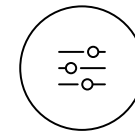

## Smart logs

- Logs parameter and sensor values of the complete extrusion process in a table
- Shows only the information you're interested in
- Keep a better overview: Information will be hidden without significant changes to the previous value
- Lets you create your own formula to be logged (e.g., temperature difference between first and last sensor)

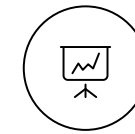

## Specific mechanical energy

- Device-independent process characteristic
- Automatic calculation of the SME within the MetaBridge environment supports you in investigations with the intention of process scale-up



## Correlation

- Compare a multitude of measurements with the correlations add-on feature to obtain an optimal understanding of your materials
- MetaBridge automatically creates smart correlations in the background and sends monthly email reports for quality control

# Get Full Control of Your Extrusion Process

With the TwinLab series, you get time-resolved recording of process variables for your entire extrusion process. Our extruder isn't just for laboratory or pilot-scale processing – it's also a powerful measuring device. Gain unparalleled insights into your processes, surpassing what's achievable with standard production machines.

Measured variables such as pressure and temperature can be determined in the extrusion dies as well as along the extruder barrel, and are visualized in the extruder software to evaluate the plasticizing and mixing behavior.

Comprehensive overview across the development of an extrusion process



## Drive and extrusion parameters

- Screw speed
- Load capacity of the drive
- Current torque (for modular design using a MetaStation torque rheometer)
- Throughputs of feeders and pumps

## Process visualization of parameters for downstream peripherals

- Take-off speeds
- Volume flow (when using a downstream melt pump)

## Measuring dies and devices

- Measurement of dispersibility in thermoplastic compounds according to DIN EN ISO 23900-5
- Inline-viscosity measurement
- Results of the optical quality analysis on extruded films
- Dimensions of the extrudate
- Dies and devices for polymer, food, pharma, and battery applications

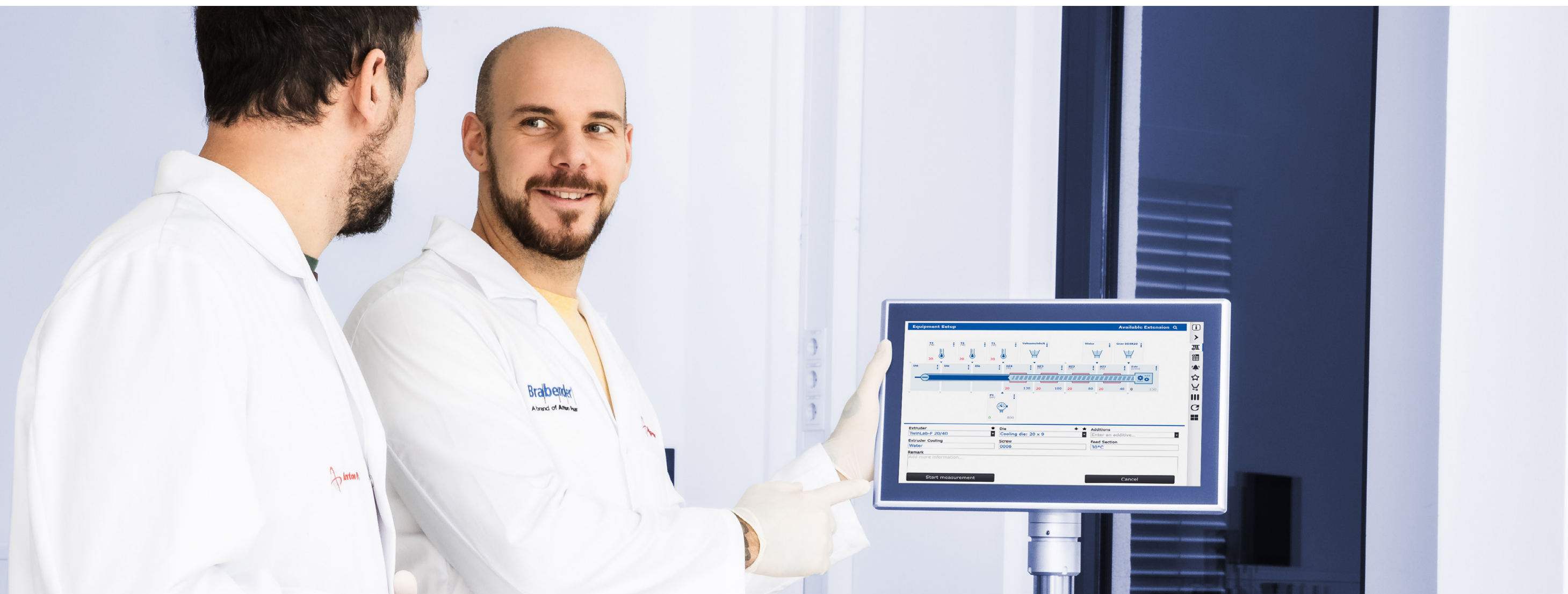

# Customize Your Screw Configuration

The Brabender TwinLab series offers a wide selection of customizable screw configurations depending on your specific requirements.

## Challenges associated with screw configurations



### Diversity of materials

Compounding covers the processing of a wide variety of materials, from liquids and polymers to pasty masses with highly abrasive ceramic particles.

### Shear stress input

The screw geometry influences the shear stress applied to the material. In extrusion, shear input can be increased or, for shear-sensitive formulations, reduced, depending on the application.

### Conveying characteristics

When creating a screw configuration, you need to consider the feeding zones used and the properties of the added substances. This means that it must be possible to influence the pressure profile as well as the conveying behavior or the residence times along the extrusion screws.

## Key features of the TwinLab screw assembly

- Segmented screws for use in co-rotating and counter-rotating extrusion processes
- Possibility of adapting the screw element arrangement to the requirements for each application
- Also available with special resistance to corrosive and abrasive compounds
- Wide selection of screw elements to optimize the conveying, mixing, and dispersion process
- Possibility of shortening the screw length to reduce the residence time due to flexible use of several feeding zones
- The lengthwise separation of the TwinLab series barrels enables easy access to the unit for evaluating and adjusting the screw setup for conveying and mixing behavior.

# Dosing Systems for a Range of Applications

Ensure consistent feedstock delivery with TwinLab's integrated dosing units for twin-screw extruders. A variety of configurations empowers you to tackle complex compounding challenges, optimized for throughput and material properties such as flowability and bulk density.

Gravimetric feeder

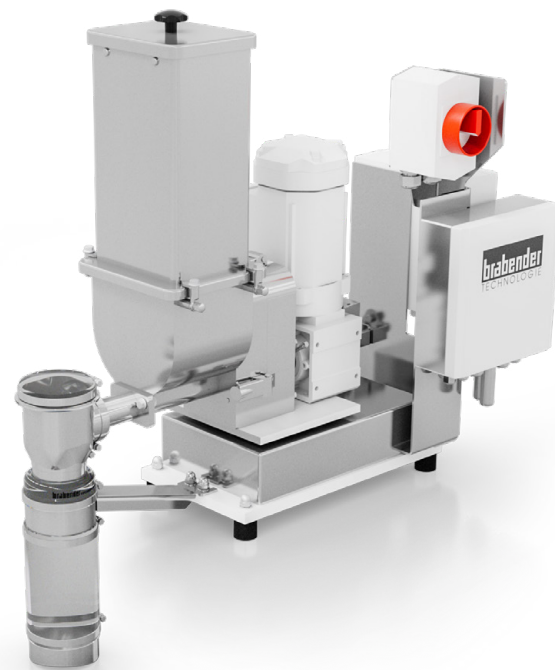

## Powder and pellet feeders

Pellet and powder dosing systems are most commonly used in compounding and can be operated in volumetric and gravimetric mode. With a gravimetric feeder, you know throughput over time. It also enables precise development of recipes and guarantees stable mixing ratios in the production of final compounds. Depending on the size and shape of the granulates and powders, the combination of conveying pipe and conveying screw is adapted to the application in terms of dimensions and design.

Vertical force feeder



## Fiber feeders

The stable dosing of fibers is especially challenging in compounding on a laboratory scale. In addition to free-fall pellet and powder feeders, specific fiber feeders can also be used as part of the TwinLab series.

Side feeder

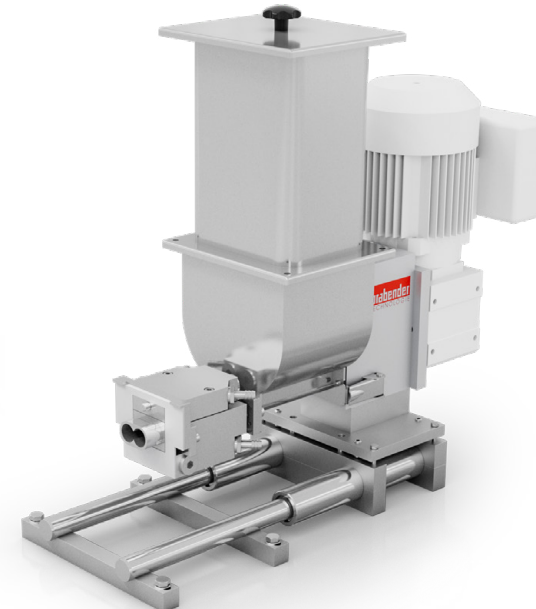

## Dosing systems for liquids and pastes

The TwinLab series offers special dosing systems for liquid and pasty substances. The portfolio includes piston and eccentric pumps in various sizes for low-viscosity, as well as high-viscosity liquids.

Side feeder

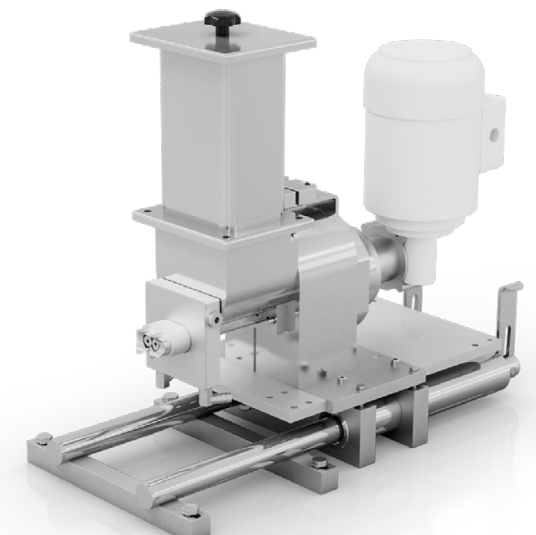

## Vertical forced feeder

Vertical forced dosing is a dosing system designed specifically for powdery and gritty materials in food and feed applications. However, vertical forced feeding can also be used in non-food applications for raw materials with low flowability and low bulk density. A vertically arranged screw in the hopper conveys the material into the extruder. A simultaneously rotating agitator supports the transportation of the material.

## Side feeder

In addition to the usual material feeding via the upper cylinder opening of the extruder, the TwinLab series side feeders can be used to feed powder and fibers via side openings, which cannot be fed using the usual free-fall variant due to their material-specific properties. The materials are conveyed into the extruded compound by a pair of conveyor screws.

# Extrusion Dies

There's a perfect extrusion die for every application – precision-engineered and manufactured to the highest quality standards.

We have you covered with special dies too – from plant-based applications to co-extrusion.

For plastics processing, you can increase the process pressure available for feeding the extrusion dies by using a melt pump installed between the extruder and extrusion die.

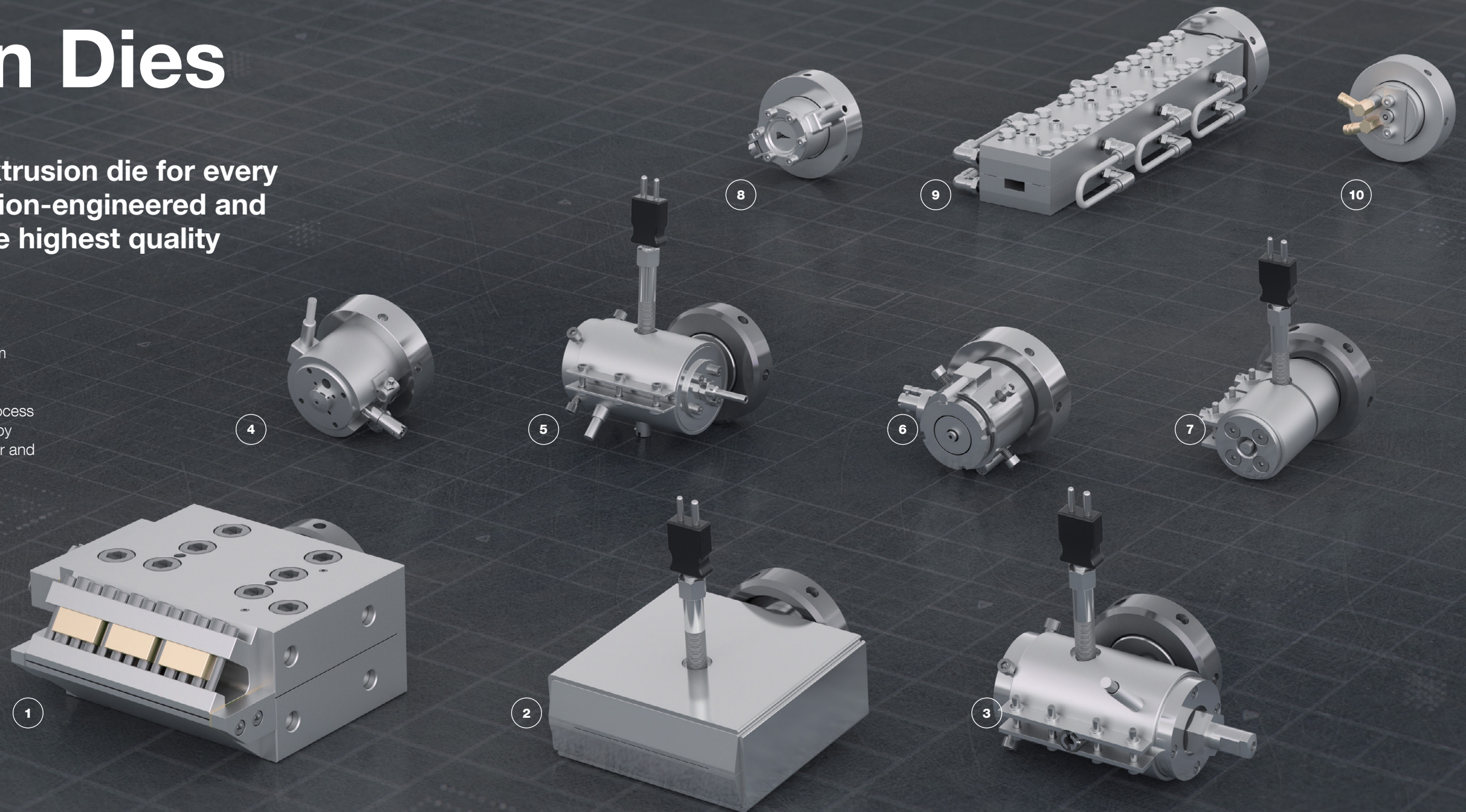

1

## Flat film dies (flex lip)

Flat film dies in different sizes with adjustable flexible lip at the die outlet

2

## Flat film dies (fixed gap)

Flat film dies in different sizes with fixed gap at the die outlet

3

## Wire coating dies

Coating dies to cover a core material, such as metallic wires, with extruded materials

4

## Round strand dies

Round shaped dies for extrusion of semi-finished goods in small scale

5

## Blown film dies

Preparation of blown film in combination with an appropriate blown film tower

6

## Tubing dies

Extrusion dies for the production of round shaped tubes with different diameters

7

## Rheological capillary dies

Measuring dies for continuous and inline determination of shear rate and temperature-dependent viscosity

8

## Garvey dies

Special standard-compliant solutions for characterizing extruded materials – e.g., purity (filtrate test), dimensional accuracy (Garvey)

9

## Modular cooling dies

Modular die system for the production of texturized plant proteins with meat-like texture on laboratory scale

10

## Pasta dies

Air or water-cooled die head for developing and processing pasta dough products

# Downstream Equipment

The TwinLab series in combination with downstream devices offers an intelligent, fully integrated, complete solution. Adjust and record the corresponding control parameters and measured variables of all peripheral devices in the software and display them in the process diagram.



1

**Conveyor belt**  
Conveying and air cooling the extrudate before winding or pelletizing

2

**Water bath**  
Cooling the extrudate before winding or pelletizing

3

**Pelletizer**  
Cutting an extruded strand of a compound into granules for subsequent further processing

4

**Winder**  
Take-off of extruded strands and winding of the extrudate on a coil

5

**Flat film take-off**  
Downstream device for the take-off and winding of extruded flat films with water or oil tempered chill rolls

6

**Wire take-off**  
Take-off for coated wires produced by means of a wire coating die

7

**Blown film take-off**  
Take-off and winding of extruded blown film, equipped with an integrated monitoring system for continuous diameter control of the extruded hose

8

**Univex with film quality analyzer**  
Cast film take-off unit with downstream device for optical evaluation of the quality of an extruded flat or blown film

9

**Laser measuring device**  
Measurement of the outer dimensions of the extrudate to monitor dimensional accuracy and evaluate the stability of the extrusion process

10

**Cutting device**  
Connected directly to the extrusion die device for cutting food and feed extrudates

# Modular Design for Maximum Flexibility

Experience the versatile modular TwinLab series in sizes 12/36D and 20/40D, paired with the MetaStation drive unit. Easily switch between twin-screw, single-screw, or mixer attachments to enable multiple applications with one tabletop or stand drive unit.

## Measuring mixer features

- Benefit from discontinuous production of homogeneous mixtures of polymers, elastomers, and ceramics
- Measure speed, torque, and temperature during the mixing process
- Evaluate flow behavior, heat, and shear stability or plasticizer absorption of PVC dry blends
- Conduct mixing tests according to international standards for plastics and rubber
- Learn the behavior of the material during processing (e.g., extrusion)



## Single-screw extruder

- Process finished compounds and recipes without additional mixing
- Measure speed, torque, and temperature during mixing
- Use in high-pressure applications requiring torque measurement during processing or testing
- Benefit from continuous production of test specimens (strands, tapes, tubes, and films)
- Perform continuous viscosity measurements on plastic compounds



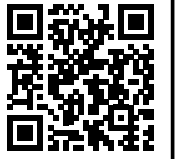

Find out more

# Reliable. Compliant. Qualified.

Our well-trained and certified technicians are ready to keep your instrument running smoothly.

	TwinLab B-TSE-A 12/36	TwinLab B-TSE-A 20/40
	Modular	
Throughput <sup>1)</sup>	0.06 kg/h to 5 kg/h	0.5 kg/h to 20 kg/h
Screw diameter D	12 mm	20 mm
L/D	36	40
Diameter ratio Do/Di	1.43	1.60
Max. screw torque	2 x 15 Nm	2 x 40 Nm
Torque density / specific torque	12.96 Nm/cm <sup>3</sup>	8.82 Nm/cm <sup>3</sup>
Max. screw speed	740 min <sup>-1</sup>	1,600 min <sup>-1</sup>
Max. processing pressure	150 bar	300 bar
Max. processing temperature <sup>2)</sup>	450 °C	450 °C
Top openings	0 D   10 D   27 D	0 D   10 D   20 D   30 D
Side openings	12 D	12 D   22 D
Power supply <sup>3)</sup>	3 x 230 V   50/60 Hz   32 A   PE 3 x 400 V   50/60 Hz   32 A   N + PE	3 x 230 V   50/60 Hz   63 A   PE 3 x 400 V   50/60 Hz   63 A   N + PE
Dimensions <sup>4)</sup> (W x H x D)	1,120 mm x 360 mm x 485 mm (without support frame) 1,130 mm x 1,140 mm x 585 mm (with support frame)	1,350 mm x 1,160 mm x 730 mm
Weight	175 kg	323 kg

	TwinLab B-TSE-S 20/40	TwinLab B-TSE-S 30/40
	Standalone	
Throughput <sup>1)</sup>	0.5 kg/h to 20 kg/h	5 kg/h to 100 kg/h
Screw diameter D	20 mm	30 mm
L/D	40	40
Diameter ratio Do/Di	1.60	1.54
Max. screw torque	2 x 40 Nm	2 x 150 Nm
Torque density / specific torque	8.82 Nm/cm <sup>3</sup>	9.60 Nm/cm <sup>3</sup>
Max. screw speed	1,200 min <sup>-1</sup>	1,200 min <sup>-1</sup>
Max. processing pressure	300 bar	300 bar
Max. processing temperature <sup>2)</sup>	450 °C	450 °C
Top openings	0 D   10 D   20 D   30 D	0 D   10 D   20 D   30 D
Side openings	12 D   22 D	12 D   22 D
Power supply <sup>3)</sup>	3 x 230 V   50/60 Hz   76 A   PE 3 x 400 V   50/60 Hz   63 A   N + PE	3 x 400 V   50/60 Hz   160 A   N + PE
Dimensions <sup>4)</sup> (W x H x D)	1,915 mm x 1,565 mm x 515 mm	2,365 mm x 1,600 mm x 600 mm
Weight	490 kg	850 kg

1) Guide value – the real throughput is a material and process-specific variable and can be higher or lower

2) Depending on the selected cylinder and screw alloy

3) Specifications for: B-TSE-A 12/36 with MetaStation 4 drive unit | B-TSE-A 20/40 with MetaStation 8

4) Specifications for: B-TSE-A 12/36 with MetaStation 4 drive unit and mobile frame | B-TSE-A 20/40 with MetaStation 8

#### Maximum uptime

Regardless of how intensively you use your instrument, we help you keep your device in perfect shape and safeguard your investment. For at least 10 years after the discontinuation of a device, we'll provide you with any service and spare part that you might need.

#### Warranty program

We're confident in the high quality of our instruments. That's why we provide a full three-year warranty. Just make sure to follow the relevant maintenance schedule. You can also extend your instrument's warranty beyond its expiration date.

#### Short response times

We know that sometimes it's urgent. That's why we provide a response to your inquiry within 24 hours. We give you straightforward help from experienced people, not from bots.

#### Global service network

Our large service network for customers spans 85+ locations with more than 600 certified service technicians. Wherever you're located, there's always an Anton Paar service technician nearby.



