

# Essential Rheometers

MCR 53 | MCR 73 | MCR 93

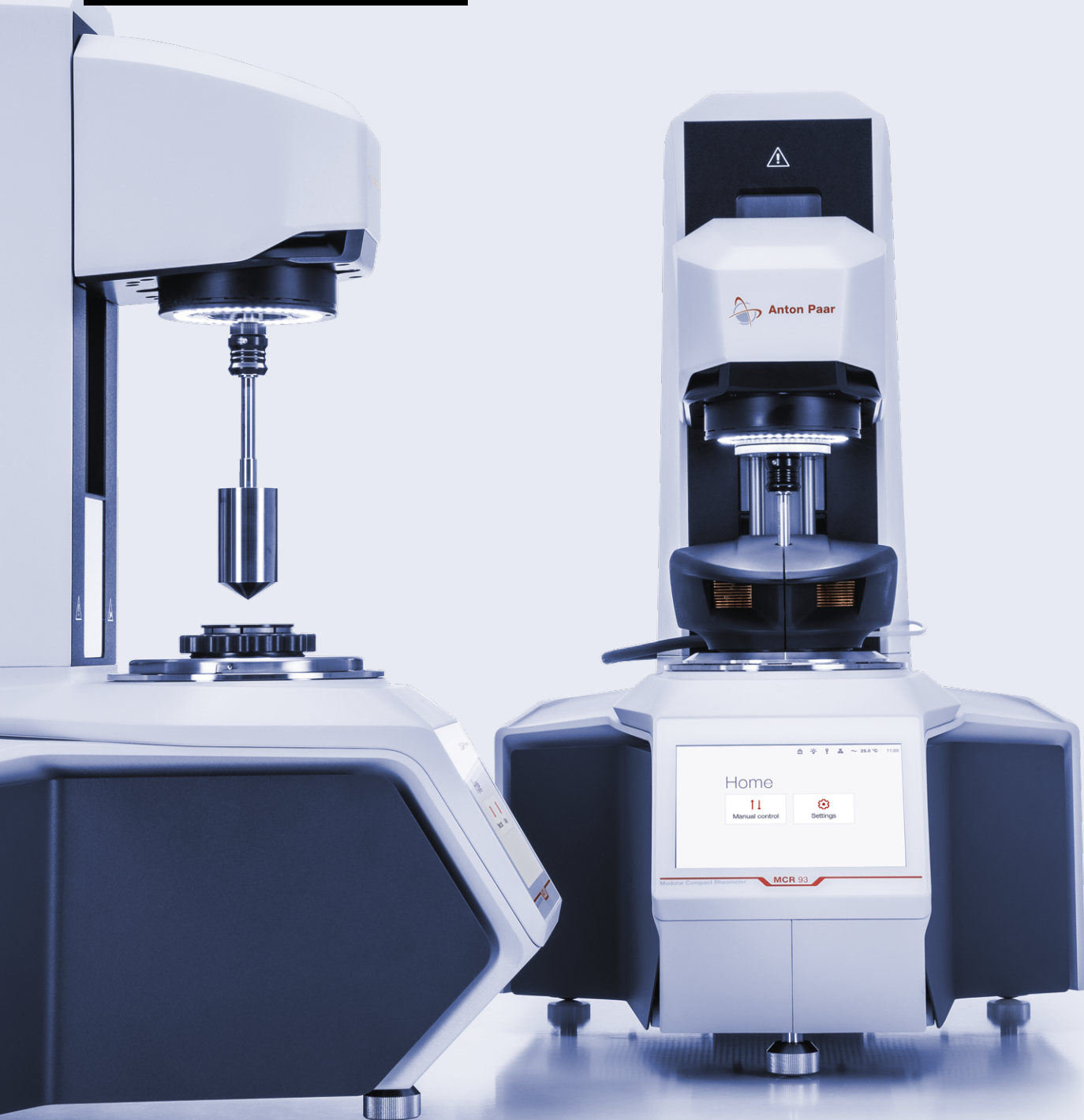

# Where Entry-Level Rheometry Benefits Me

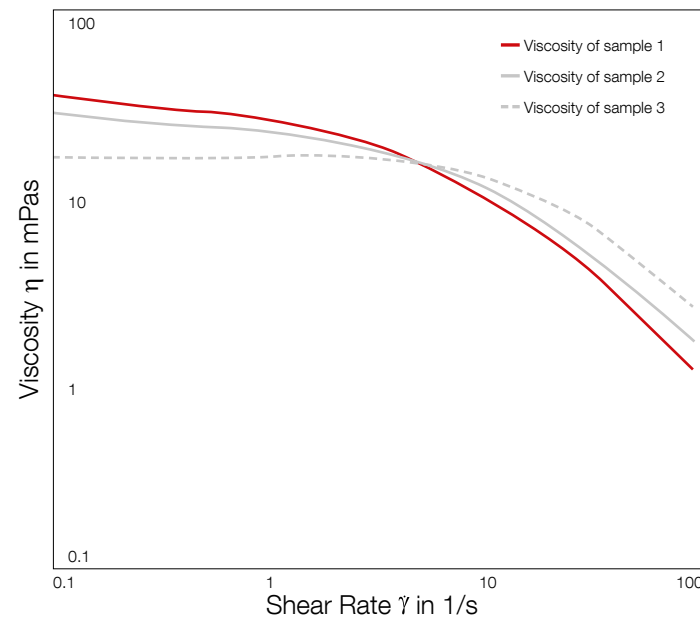

## Measure viscosity that actually matters

Viscosity is more than a single value; it shifts with shear rate and temperature. One data point won't protect you from separation, processing issues, or application failures. Full viscosity curves across low, medium, and high shear rates show how your product behaves from storage to final use.

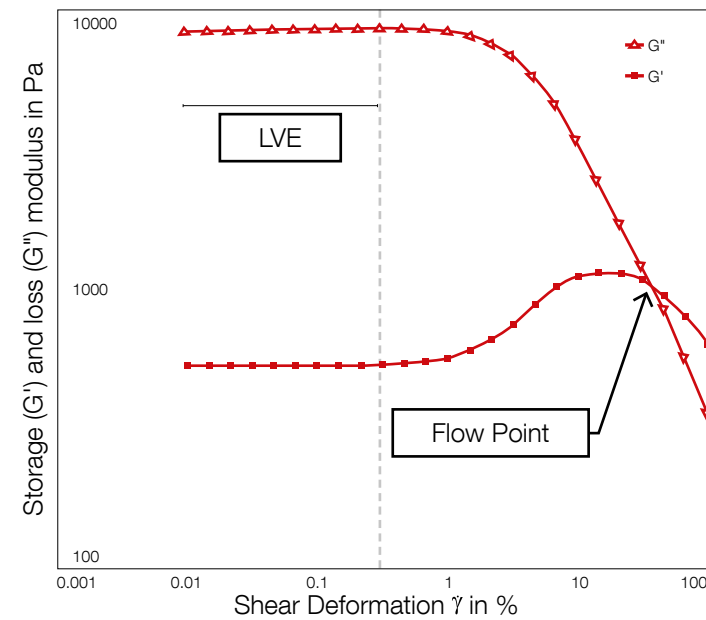

## Reveal structural strength with amplitude sweeps

Basic viscosity hides the true internal structure of complex materials. The amplitude sweep exposes how strong, fragile, or shear-sensitive your material really is. By identifying the linear viscoelastic region (LVE region) material behaviour at rest is shown. Crossover of both curves indicates the flow point where the material switches from gel-like to viscous behaviour.

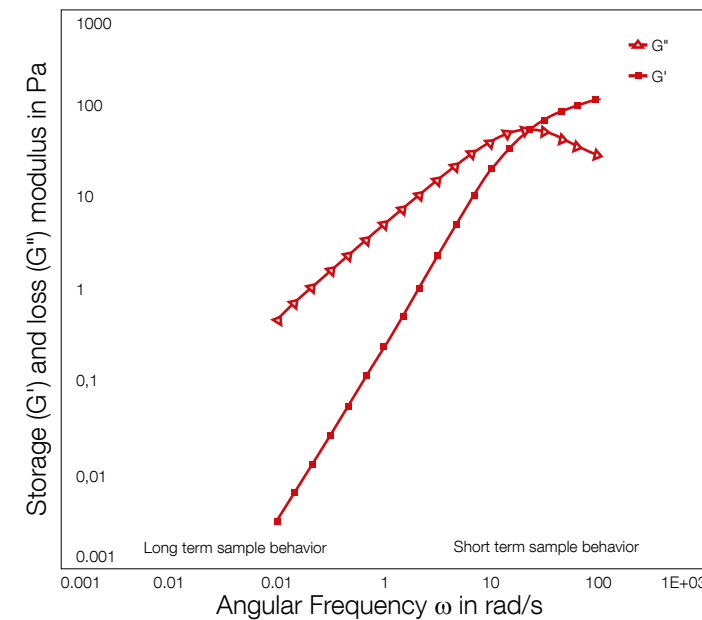

## Understand time-dependent behavior with frequency sweeps

Materials behave differently across time scales. The frequency sweep maps long-term stability and short-term performance in a single non-destructive test, revealing whether a material is more elastic, viscous, gel-like, or highly cross-linked.

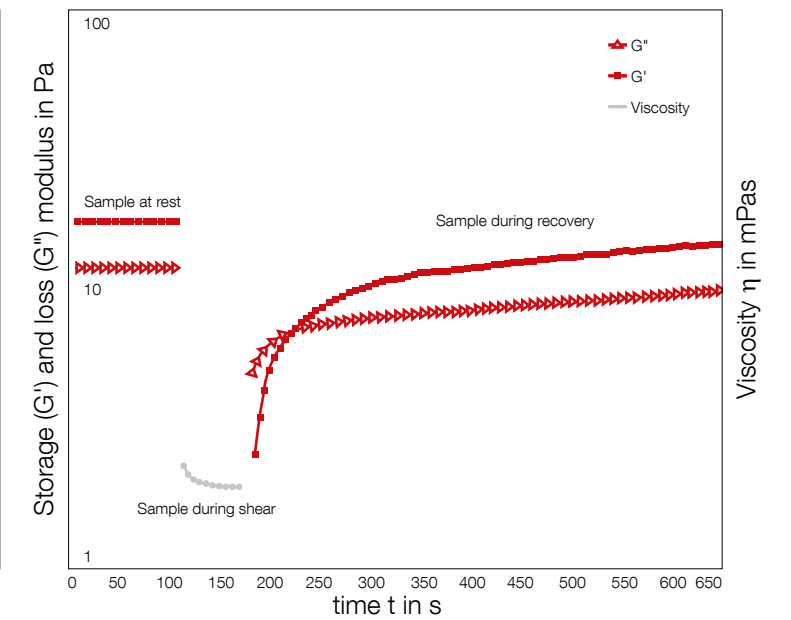

## Determine structural recovery after application with 3-interval thixotropy tests

Mixing, pumping, brushing, spraying – they all damage structure. The 3-interval thixotropy test quantifies exactly how fast and how completely your material rebuilds after shear under realistic conditions.

### Benefits

- More reliable formulations
- Stable products across their lifecycle
- Predictable performance for the end user

- Clear structural limits for robust formulation work
- Better control of gel strength, stiffness, and sensitivity
- Confidence that your products stay stable under real stresses

### Benefits

- Predict stability over time
- Optimize texture and performance under fast motions or vibrations
- Solve formulation issues with a complete viscoelastic fingerprint

- Objective, quantitative metrics for structural breakdown and recovery
- Better control of appearance or handling directly after application
- Clear comparison of formulations, raw materials, or process settings in terms of post-shear behavior

# A New Era in Rheometry

**For years, Anton Paar has set the benchmark in rheological measurement. We have pioneered entry-level rheometry, shaping the standards others follow. The new MCR 53, MCR 73 and MCR 93 carry the DNA of Anton Paar's flagship MCR instruments – trusted by scientists and industry leaders worldwide.**

## **The fastest**

Accelerate every routine. From setup to results, the MCR series delivers standard measurements up to 60 % faster. Every step – from sample preparation to the final report – is powerfully efficient.

## **Temperature mastery**

With these instruments, gradient-free temperature control technology redefines precision and sustainability. No thermostat, no compromises – just accurate, reproducible results across a temperature range from -10 °C to +220 °C.

## **The smartest**

Auto Control continuously monitors the sample behavior during a test and adjusts the control loop in real time. Combined with intuitive touchscreen operation, this creates a one-touch workflow – no presets, no guesswork.

## **Built-in adaptability**

From core QC to advanced applications like tribology and powder rheology, modularity makes every MCR a future-proof investment. Whether it's the pressurized-air-free MCR 53 or the multi-purpose MCR 93, each model evolves with your testing needs.



Find out more

# The Smartest and Fastest Entry-Level Rheometer

Overall, the MCR saves up to 60 % of time across the whole measurement process compared to any other entry-level rheometer.



## Quick boot time

The MCR starts in just six seconds, up to 40x faster than other entry-level rheometers.

## Electronic levelling

Inexplicable measurement errors due to insufficient levelling are avoided. The electronic level of the MCR is automatically saved in the measurement dataset, ensuring full confidence in your results.

## QuickConnect coupling

Measuring geometries can be coupled in seconds using just one hand.

## Toolmaster

Fully automatic recognition of measuring systems and accessories minimizes errors.

## Touchscreen operation

The integrated touchscreen provides all functions needed to prepare a test directly on the rheometer.

## Trimming mirror and TruRay

The trimming mirror and TruRay illumination provide clear 360-degree visibility for sample trimming, optimizing measurement results and sample loading.

## Auto Control

Auto Control delivers high-quality results for unknown samples without time-consuming controller presetting.

## Fastest measuring times

The MCR completes rotational and oscillatory tests up to 60 % faster than any other conventional devices on the market.

# The Most Precise Temperature Control in Entry-Level Rheometry

Our temperature control systems set the standard for precision, flexibility, and sustainability. From Peltier and electrical systems to revolutionary CoolPeltier technology, every device ensures perfectly stable conditions for reliable, repeatable results.

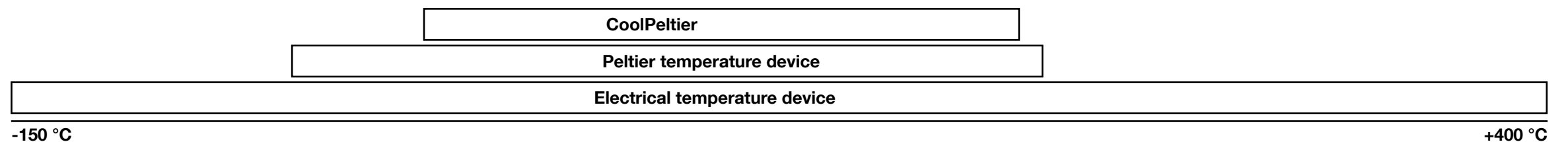
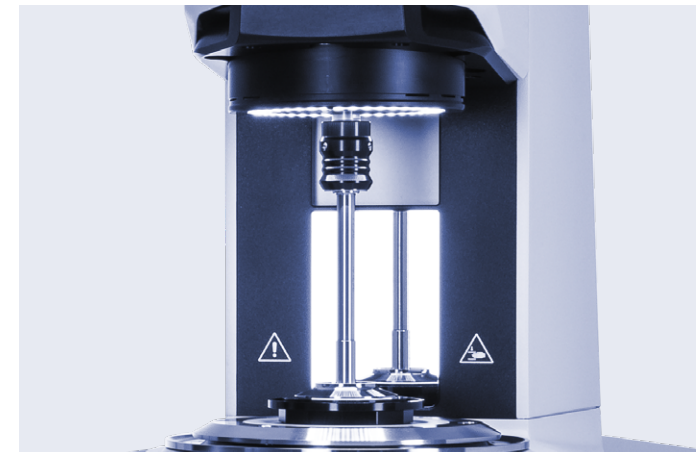
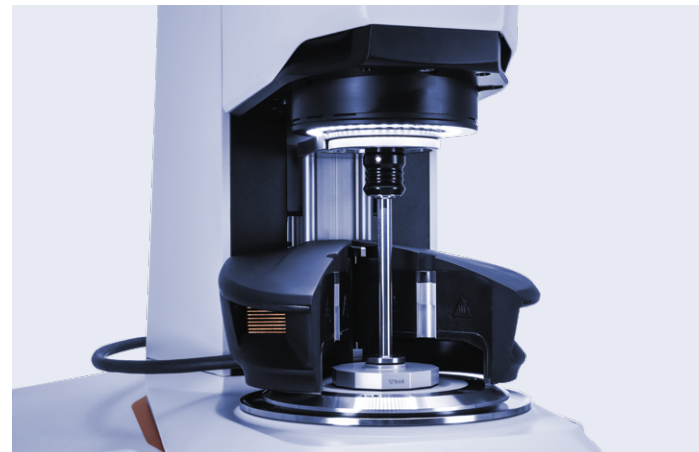

## CoolPeltier

The most efficient temperature control is achieved with CoolPeltier technology – no thermostat required – reducing costs and environmental impact.

- Like all Anton Paar temperature devices, its gradient-free range from **-5 °C to +200 °C** ensures unmatched accuracy.
- Compact, sustainable, and more capable than comparable devices, it delivers reliable results with lower investment and operating costs.

## Peltier temperature device

Compact, easily installable temperature devices that use Peltier-element heating and cooling and operate up to 220 °C feature:

- A unique temperature range from **-50 °C to +220 °C**
- Compatibility with plate-plate, cone-plate, concentric-cylinder, double-gap measuring geometries, and stirrers
- Active cooling without the need for additional low-temperature options
- Air-cooled Peltier systems available (no fluid circulator required)

## Electrical temperature device

Fast temperature devices based on electrical heating and cooling with pressurized air or fluid for temperature control provide:

- A temperature range from **-150 °C to +400 °C**
- Compatibility with plate-plate, cone-plate, concentric-cylinder, double-gap measuring geometries, and stirrers
- Additional heated hoods for eliminating temperature gradients

# The Most Adaptable Entry-Level Rheometer

These rheometers set new standards in flexibility, with modularity that expands from core QC applications to advanced areas.

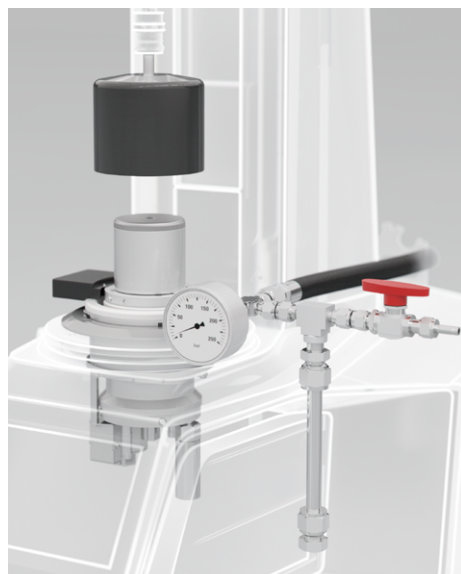

## Pressure cell

Pressure cells for up to 170 bar (up to 200 °C) operate in self- or gas-pressurization mode. Applications include the study of polymer behavior with supercritical CO<sub>2</sub> and the impact of high pressure on motor oils.



## Dielectric rheological device (DRD)

DRDs combine rheology with dielectric and impedance spectroscopy. They provide insights into internal structure via dielectric spectrum interpretation. Typical applications include battery slurries, adhesives, resins, and polar materials. Various LCR meters can be combined.



## Starch cell

A starch cell for analyzing starch gelatinization or pasting behavior simulates temperature and pressure conditions of food production processes, with a uniquely small sample volume of around 18 mL and an optional starch pressure cell up to 30 bar and 160 °C.



## Building material cell (BMC)

With BMCs, the flow properties of samples containing large particles (>1 mm) – typically found in building materials, food products, or slurries – can be measured reliably. Resistant to abrasive materials, they prevent sample slippage and improve mix-up effects to avoid separation.



## Entry-level tribometer

The precise motion and normal-force control of MCR tribometers enables advanced tribological measurements. Traditional tribological tests can be extended by opening up entirely new measuring ranges on a single instrument. Breakaway forces can be measured seamlessly, and Stribeck curves can be plotted over multiple decades of sliding speeds.



## Entry-level powder rheometry

An MCR rheometer combined with the powder shear cell or powder flow cell enables fundamental powder characterization. The unique cells deliver straightforward results for flowability and compressibility analysis of powders in the consolidated and aerated state as well as density measurements of solid samples at ambient conditions.

# The Choice Is Yours



## MCR 53

### Entry-level instrument for QC

- No need for pressurized air; place it wherever you need it
- Measurements in rotation and special-application oscillation
- Ideal for measuring sample flow behavior



## MCR 73

### Entry-level rheometer with elevated sensitivity

- Highly accurate air-bearing motor (minimum torque 100 nNm)
- For measurements in both rotation and oscillation
- Ideal for investigation of sample structure



## MCR 93

### Fully-fledged QC and entry-level product development

- Highly accurate air-bearing motor (minimum torque 80 nNm)
- Advanced testing thanks to normal force control
- Entry-level platform for tribology, powder rheology, and more



## Specialized variants

### Specialized variants for asphalt, bitumen and polymer rheometry

- Two specialized variations: SmartMelt 73 and SmartPave 93 rheometers
- Precise rheology for polymer melts and asphalt binders
- Ideal instruments for QC and product development in the respective areas

	MCR 53	MCR 73	MCR 93
<b>Specifications</b>			
<b>Bearing design</b>	Mechanical	Air, fine-pored carbon	
<b>Motor design</b>	Electronically commutated (EC) permanent magnet synchronous motor		
<b>Displacement transducer</b>	High-resolution optical encoder		
<b>Normal Force measurement design</b>	×	×	360° capacitive sensor, non-contacting, fully integrated in bearing
<b>Min. torque (rotation)</b>	200 µNm	100 nNm	80 nNm
<b>Min. torque (oscillation)</b>	200 µNm	100 nNm	80 nNm
<b>Max. torque</b>	125 mNm	160 mNm	160 mNm
<b>Torque resolution</b>	5 nNm		
<b>Angular deflection resolution</b>	8 nrad		
<b>Min. angular velocity<sup>1)</sup></b>	10 <sup>-8</sup> rad/s		
<b>Max. angular velocity / Max. speed</b>	157 rad/s   1,500 rpm	261 rad/s   2,500 rpm	
<b>Min. frequency<sup>2)</sup></b>	10 <sup>-7</sup> Hz		
<b>Max. frequency</b>	100 Hz		
<b>Normal force range</b>	×	×	0.001 N to 50 N
<b>Normal force resolution</b>	0.4 mN		
<b>Auto Control</b>	✓	✓	✓
<b>TruStrain</b>	×	×	×
<b>TruRate</b>	×	×	×
<b>Dimensions (W x H x D)</b>	442 mm x 725 mm x 596 mm		
<b>Weight</b>	45 kg		

Trademarks: RheoCompass (9177015), SmartPave (16731556), Toolmaster (3623873), TruRay (15273915), CoolPeltier (9177056)

✓ Included    × Not included

1) Depending on measuring point duration and sampling time, practically any value is achieved  
2) Set frequencies below are of no practical relevance due to the measuring point duration >1 day

## Reliable. Compliant. Qualified.



**Our well-trained and certified technicians are ready to keep your instrument running smoothly.**

Maximum uptime | Warranty program | Short response times | Global service network

# The Rheo Academy



Find out more

### Sign up for our rheology courses and webinars

We regularly offer courses at our global subsidiaries and also organize online courses or exclusive group courses for customers on request.

Learn the basics of rheology, optimize your work with the RheoCompass software, and gain application-specific knowledge. You can also learn more about specialist subjects and meet our experts for discussions online by taking part in one of our free webinars.

### Enjoy access to an extensive database of knowledge

As a customer, enjoy access to a large database of useful application reports, product documentation, and tutorial videos. Benefit from our comprehensive background knowledge on rheological theory (e.g., through our wiki and the book *Applied Rheology* by renowned expert Thomas Mezger).

### Get in touch with our experts

We provide excellent service and support. With Anton Paar subsidiaries and numerous partners worldwide, a rheological expert is close to you and happy to help. Call us for advice on test definitions or to discuss the rheological challenges you face.



